

OPTIMISED PERFECTION



UNSURPASSED PERFORMANCE IN ANY APPLICATION

Grundfos offers an almost limitless range of close-coupled (NB/NBG) and long-coupled (NK/NKG) end-suction pumps, whose robustness and reliability make them ideal for use in even the most demanding environments.

COMBINING TRADITION AND FORWARD THINKING

Despite their sturdy build and solid appearance, the Grundfos end-suction pumps are ready to sprint into the top of their field. Over the years the pumps have been carefully optimised and refined to offer unsurpassed energy efficiency and performance as well as amazing flexibility.

SURVIVAL OF THE FITTEST

The Grundfos end-suction pumps made from cast iron are designed to work hard in demanding environments, where only the fittest pumps will

survive in the long run. Whatever is running through the pipes will be handled effortlessly by the unique end-suction range. In applications where there is a high risk of corrosion, a range of stainless steel NB/NK variants is available as well.

APPLICATION AREAS

The impressive range of Grundfos end-suction pumps is compatible with an array of application areas, including:

- > Water intake
- > Heating/district heating
- > Industrial pressure boosting
- > Industrial liquid transfer
- > Air-conditioning
- > District cooling
- > Irrigation
- > And many more.

10 and 16 bar flanges available
= for EN733 and ISO2858 designated applications

Optimised pump hydraulics
= EuP Directive 2009/125/EC[MEI] ready

O-ring seal between pump housing and cover
= no risk of leakage

Single and double seal versions available
= for handling numerous kinds of liquids

All-stainless steel shafts
= improved corrosion resistance

Standard and heavy duty bearing design
= to meet various life-time demands

NK/NKG

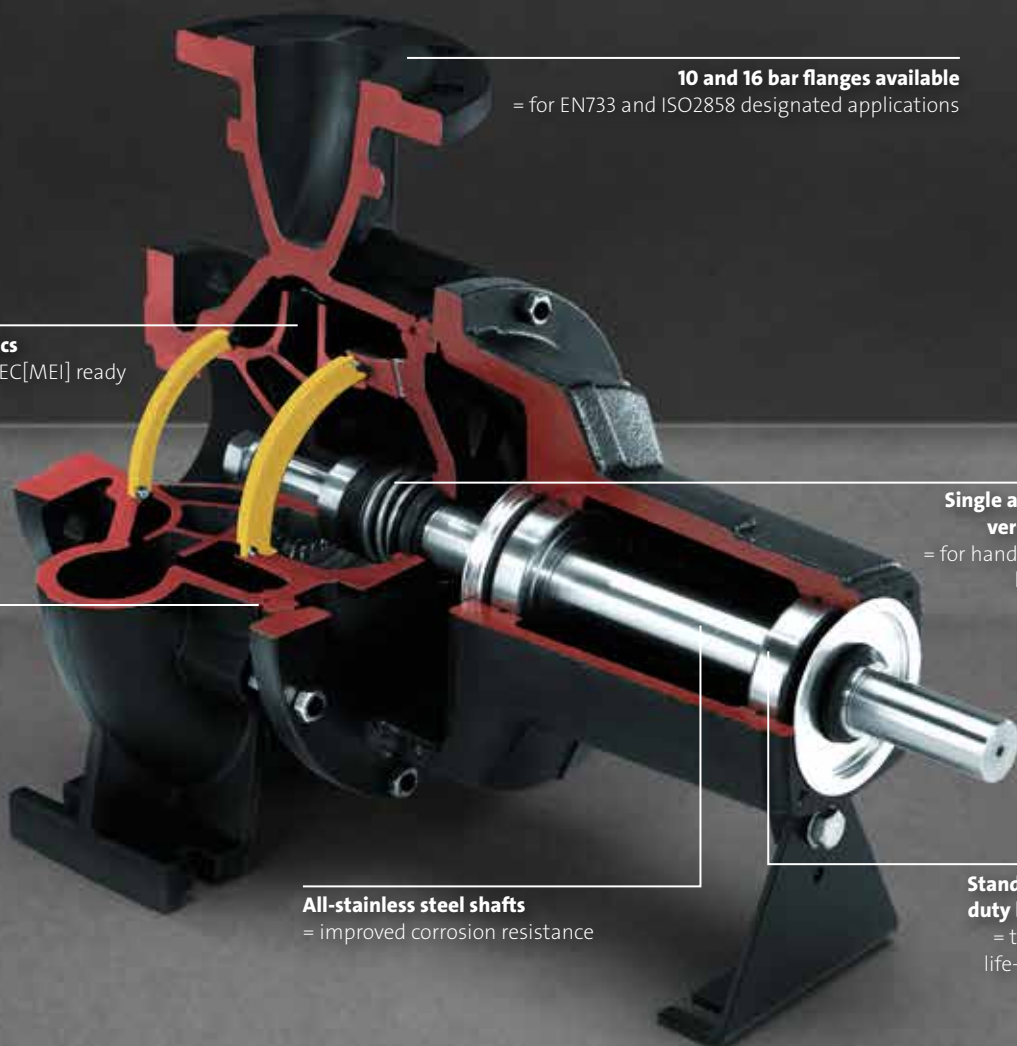

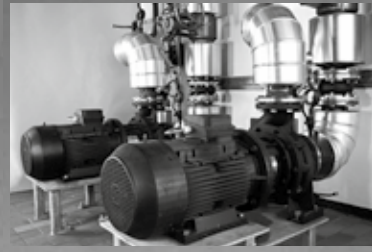

BENEFITS IN BRIEF

ENERGY EFFICIENCY

All Grundfos end-suction pumps can be equipped with motors that carry the Grundfos Blueflux® label, representing the very best from Grundfos within energy-efficient motor technology.

RELIABILITY

Backed by comprehensive pump know-how and carefully selected materials, the Grundfos end-suction range is renowned for its outstanding reliability.

COMPLETE RANGE

The range comprises a full series of close-coupled and long-coupled end-suction pumps in both cast iron and stainless steel.

FLEXIBILITY

Grundfos end-suction pumps can be configured and optimised for seamless operation in any application.

DEMANDING ENVIRONMENTS

Grundfos end-suction pumps handle even the most demanding liquids and environments. Reliable, efficient – a pump you can trust.

GLOBAL REACH

As a truly global supplier Grundfos offers delivery, service and commissioning expertise on every continent, and always in the local language.

O-ring seal between pump housing and cover
= no risk of leakage

Optimised pump hydraulics
= EuP Directive 2009/125/EC[MEI] ready

All-stainless steel/stub-shaft design
= improved corrosion resistance

Motor supports – as a part of the delivery
= for easy installation (above 7.5 kW)

10 and 16 bar flanges available
= for EN733 and ISO2858 designated applications

Close-coupled design
= no alignment needed

Grundfos Blueflux® motor technology
= high efficiency motors IE2/IE3/EI4 or MGE

NB/NBG

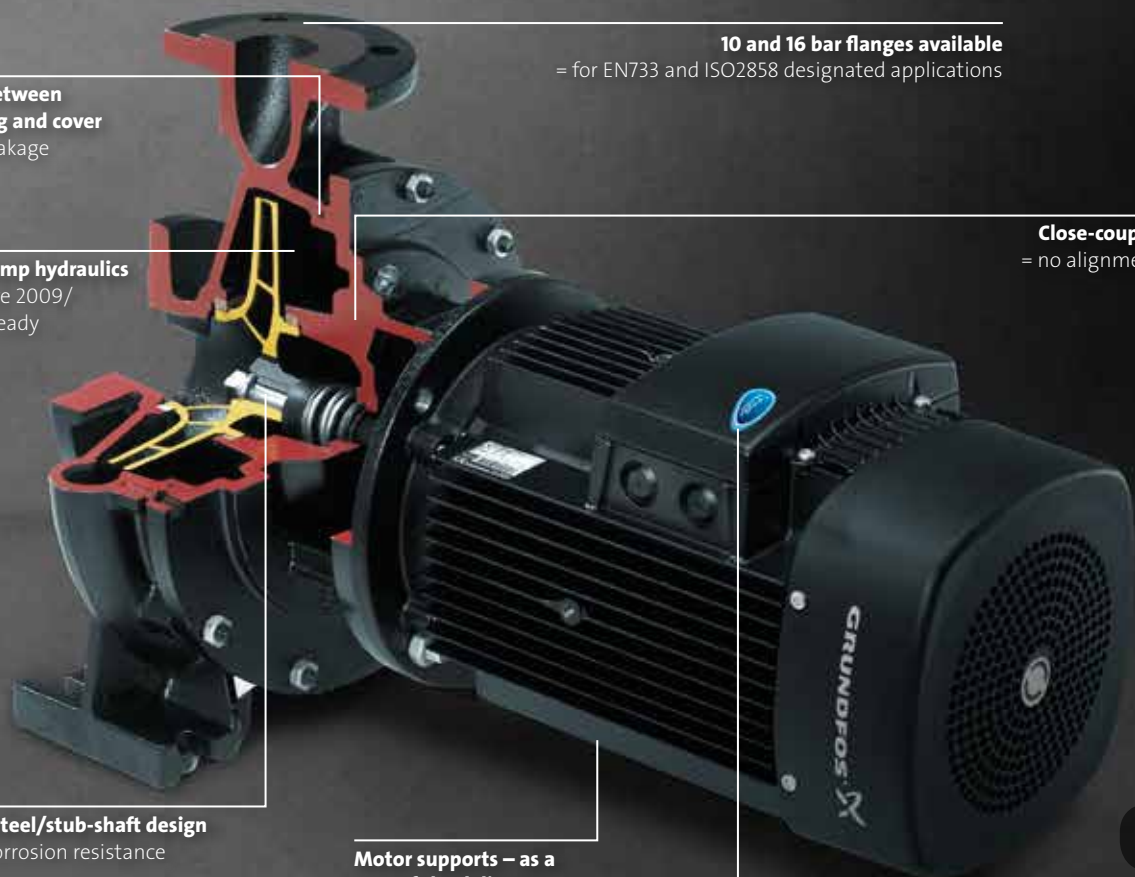

GRUNDFOS NB/NBG/NK/NKG

Grundfos offers an impressive range of close-coupled (NB/NBG) and long-coupled (NK/NKG) end-suction pumps, whose sturdiness and reliability make them ideal for use in virtually all applications, including the most demanding environments. The pumps feature IE3 and IE2 motors as standard configurations, and when delivered with integrated frequency converter (MGE), the maximum efficiency is ensured throughout all operating hours.

Application areas include:

- > Water supply
- > Heating/district heating
- > Industrial pressure boosting
- > Industrial liquid transfer
- > Air-conditioning
- > District cooling
- > Irrigation

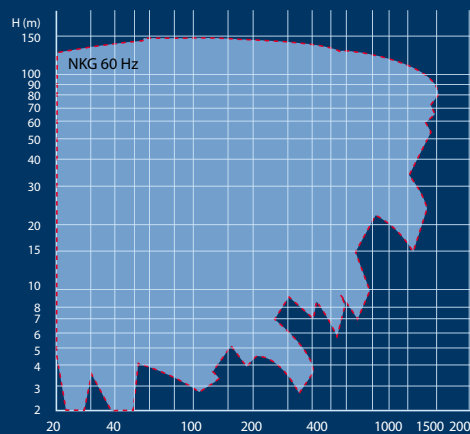

TECHNICAL DATA

| | NB | NK | NBG | NKG |
|---------------------------|------------------------|------------------------|------------------------|------------------------|
| Flow (max.) | 1100 m ³ /h | 1500 m ³ /h | 1100 m ³ /h | 1500 m ³ /h |
| Head (max.) | 105 m | 150 m | 150 m | 150 m |
| Liquid temperature | 0 °C to +140 °C | 0 °C to +140 °C | 0 °C to +140 °C | 0 °C to +140 °C |
| Max. pressure | 10/16 bar (1600 kPa) | 10/16 bar (1600 kPa) | 16 bar (1600 kPa) | 16 bar (1600 kPa) |

For additional information, please refer to Grundfos WebCAPS or go to www.grundfos.com.



The Grundfos Blueflux[®] technology label is your guarantee for the best-in-class motor solution from Grundfos in terms of performance and energy consumption. Products with Grundfos Blueflux[®] label either meet or exceed international legislation regarding motor efficiency.